

*Cordless Phone*

**TELECALL**

**Model TLC-353**

**Dual Handset**



**USER'S GUIDE**

*ENGLISH*



### **IMPORTANT SERVICE INFORMATION**

Read this manual before attempting to setup or use this instrument. It contains important information regarding safe installation and use. Keep this manual for future reference. Also save the carton, packing and proof of purchase to simplify and accelerate any needed action.



#### **WARNING**

To prevent fire or shock hazard, do not expose this product to rain or any type of excess moisture. If it is accidentally dropped into water, the AC adapter should immediately be unplugged from the wall along with the telephone line cord.



**THIS SYMBOL IS INTENDED TO ALERT THE USER OF THE PRESENCE OF IMPORTANT OPERATING AND MAINTENANCE (SERVICING) INSTRUCTIONS IN THE OWNER'S MANUAL.**

## **TLC-353**

### **CARTON CONTENTS**

- TLC-353 Base and Handset
- Rechargeable Ni-Cd Battery Pack
- Telephone Line Cord
- AC Adaptor
- User's Manual
- Warranty Card

## **SAVE THESE INSTRUCTIONS**



### **IMPORTANT SAFETY** **INSTRUCTIONS**

When using your telephone equipment, basic safety precautions should always be followed to reduce the risk of fire, electric shock, and injury to persons, including the following:

1. Read and understand all instructions.
2. Follow all warnings and instructions marked on the product.
3. Unplug this product from the wall outlet before cleaning. Do not use liquid cleaners or aerosol cleaners. Use a damp cloth for cleaning.
4. Do not use this product near water, for example, near a bathtub, wash bowl, kitchen sink, or laundry tub, in a wet basement or near a swimming pool.
5. Do not place this product on an unstable cart, stand, or table. The product may fall, causing serious damage to the product.
6. Slots and openings in the cabinet and the back or bottom are provided for ventilation, to protect it from overheating. These openings should never be blocked or covered. The openings should never be blocked by placing the product on the bed, sofa, rug, or other similar surface. This product should never be placed near or over a radiator or heat register. This product should not be placed in a built-in installation unless proper ventilation is provided.
7. This product should be operated only from the type of power source indicated on the marking label. If you are not sure of the type of power supply to your home, consult your dealer or local power company.
8. Do not allow anything to rest on the power cord. Do not locate this product where the cord will be abused by persons walking on it.
9. Do not overload wall outlets and extension cords as this can result in the risk of fire or electric shock.
10. Never push objects of any kind into this product through cabinet slots as they may touch dangerous voltage points or short out parts that could result in a risk of fire or electric shock. Never spill liquid of any kind on the product.
11. To reduce the risk of electric shock, do not disassemble this product, but take it to a qualified service contractor when some service or repair work is required. Opening or removing covers may expose you to dangerous voltages or other risks. Incorrect reassembly can cause electric shock when the appliance is subsequently used.
12. Unplug this product from the wall outlet and refer servicing to qualified service personnel under the following conditions:
  - A. When the power supply cord or plug is damaged or frayed.
  - B. If liquid has been spilled into the product.,
  - C. If the product has been exposed to rain or water.
  - D. If the product does not operate normally by following the operating instructions. Adjust only those controls that are covered by the operating instructions. Improper adjustments of other controls may result in damage and will often require extensive work by a qualified technician to restore the product to normal operation.
  - E. If the product has been dropped or the cabinet has been damaged.
  - F. If the product exhibits a distinctive change in performance.
13. Avoid using a telephone (other than a cordless type) during an electrical storm. There may be a remote risk of electric shock from lightning.
14. Do not use the telephone to report a gas leak in the vicinity of the leak.

 **INSTALLATION  
PRECAUTIONS**

1. Never install telephone wiring during a lightning storm.
2. Never install telephone jacks in wet locations unless the jack is specifically designed for wet locations.
3. Never touch uninsulated telephone wires or terminals unless the telephone line has been disconnected at the network interface.
4. Use caution when installing or modifying telephone lines.

 **MAINTENANCE**

1. Use a damp cloth to clean the plastic cabinet. A mild soap will help to remove grease or oil. Never use polish, solvents, abrasives or strong detergents since these can damage the finish.
2. Your phone should be situated away from heat sources such as radiators, heaters, stoves or any other appliance that produces heat.

 **CAUTION**

There is the risk of explosion if the battery is replaced by an incorrect type. Dispose of used batteries according to the instruction. Read and follow these instructions:

1. Use only the 3.6V, 450mAh, Ni-Cd battery pack .
2. Do not dispose of the battery in a fire. The cell may explode. Check with local codes for possible special disposal instructions.
3. Do not open or mutilate the battery. Released electrolyte is corrosive and may cause damage to the eyes or skin. It may be toxic if swallowed.
4. Exercise care in handling the battery in order not to short the battery with conducting material such as rings, bracelets and keys. The battery or conductor may overheat and cause burns.
5. Recharge only the battery provided with or identified for use with this product. The battery may leak corrosive electrolyte or explode if it is not the correct type.
6. Do not attempt to rejuvenate the battery provided with or identified for use with this product by heating them. Sudden release of the battery electrolyte may occur causing burns or irritation to eyes or skin.
7. When inserting the battery into this product, the proper polarity or direction must be observed. Reverse insertion of batteries can cause charging that may result in leakage or explosion.
8. Do not store this product, or the battery provided with or identified for use with this product, in high-temperature areas. Batteries that are stored in a freezer or refrigerator for the purpose of extending shelf life should be stabilized at room temperature prior to use after cold storage.
9. Disconnect telephone lines before installing batteries

The battery compartment door requires no modification then.

1. The door of the battery compartment should NEVER be dismantled when charging.
2. Do not TOUCH, REMOVE or INSTALL the battery pack when charging.
3. ALWAYS with the compartment door on when charging.
4. Do not charge the handset when the cover of battery compartment is missing. Call our service center before further operation.

## SAVE THESE INSTRUCTIONS



### FCC NOTICE

The FCC requires that you be advised of certain requirements involving the use of this telephone.

1. This telephone is hearing aid compatible.
2. This equipment complies with 47 CFR Part 68 requirement. On the bottom of this equipment is a label that contains, among other information, the ACTA registration number and Ringer Equivalence Number (REN) for this equipment. If requested, provide this information to your telephone company.
3. The REN is useful to determine the quantity of devices you may connect to your telephone line and still have all of those devices ring when your number is called. In most, but not all areas, the sum of the RENs of all devices should not exceed five (5.0). To be certain of the number of devices you may connect to your line, as determined by the REN, you should call your local telephone company to determine the maximum REN for your calling area.
4. If your telephone causes harm to the telephone network, the telephone company may discontinue your service temporarily. If possible, they will notify you in advance. But if advance notice is not practical, you will be notified as soon as possible. You will be advised of your right to file a complaint with the FCC.
5. Your telephone company may make changes to its facilities, equipment, operations or procedures that could affect the proper operation of your equipment. If they do, you will be given advance notice so as to give you an opportunity to maintain uninterrupted service.
6. This equipment may not be used on coin service provided by the telephone company. Connection to party lines is subject to state tariffs. (Contact your state public utility commission or corporation commission for information).
7. USOC jack type is RJ11C and the compatible jack is part 68 compliance.

**NOTICE:** If your home has specially wired alarm equipment connected to the telephone line, ensure the installation of this [equipment ID] does not disable your alarm equipment. If you have questions about what will disable alarm equipment, consult your telephone company or a qualified installer.

This device complies with Part 15 of the FCC Rules. Operation is subject to the following two conditions: (1) This device may not cause harmful interference, and, (2) this device must accept any interference received, including interference that may cause desired operation. Privacy of communications may not be ensured when using this phone.

Changes or modifications not expressly approved in writing by TELECALL PHONES may void the user's authority to operate this equipment.

Some cordless phones operate at frequencies that may cause interference to nearby TVs and VCRs; to minimize or prevent such interference, the base of the cordless phone should not be placed near or on top of a TV or VCR; and, if interference is experienced, moving the cordless telephone farther away from the TV or VCR will often reduce or eliminate the interference.



**AC ADAPTOR:** Use only with Class 2 Transformer, 9VDC output , 200mA for base unit and 9VDC output , 200mA for charger, center pin positive.

## TLC-353 CONTROLS DIAGRAM

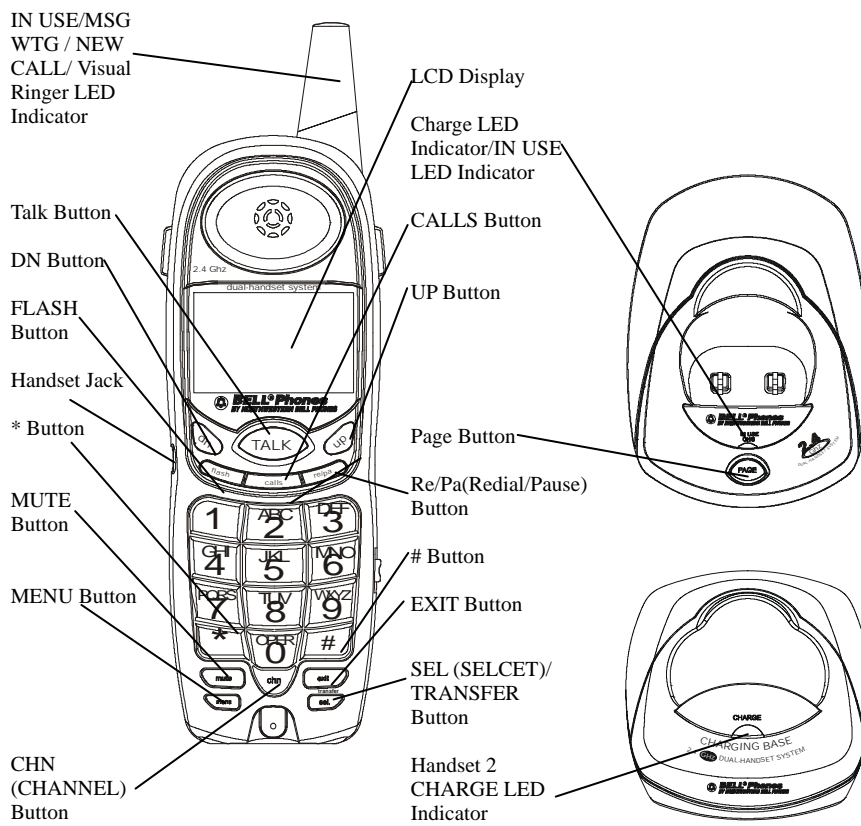

Base Unit  
(Rear View)

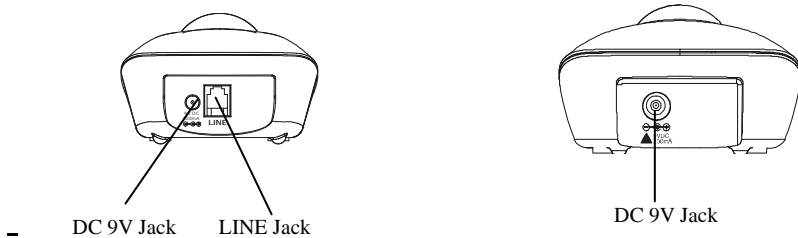

## **DESCRIPTIONS**

### *Handset Controls:*

**LCD Display** - Shows call information, phone status, prompts and Phonebook items.

**IN USE/ MSG WTG/ NEW CALL/VISUAL RINGER LED Indicator** – Lights solid whenever the handset is in TALK mode. Turns off when the handset is not in use and out of the base unit. Red LED blinks when you have call(s) and new message(s). Flashes to indicate the phone is ringing, as a signal to the user, when the ringer is switched off.

**TALK Button** - Press this button to place a call, answer a call, or end a call.

\* **Button** - In programming mode & tone dialing mode, this key is used as a normal number key. In pulse dialing mode, it is used to initiate temporary DTMF dialing.

# **Button** - During you view the caller list, press to place a long distance call or to place a local call. Allows you to change the format of displayed number.

**FLASH Button** - Momentarily hangs up the phone to access custom calling features such as Call waiting or Three-way calling provided by you local phone company.

**UP/DN Button** - Allows you to adjust the handset volume (3 steps) in TALK mode. (DN) It also allows you to view the caller list. (UP) It also allows you to view the directory.

**Microphone** - Used for speaking with callers.

**Headset Jack** – A jack located on the side of the handset used for connecting your headset to enjoy a hands-free communication.

**Re (Redial)/Pa (Pause) Button** – (Redial) Press to redial the last number you dialed. (Pause) Press to insert pause while dialing.

**EXIT Button** –This key is used to exit all models of operation and return the handset and base unit to the standby mode.

**MUTE Button** – In talk mode, this button allows you to temporarily disable the handset microphone. The LCD Display will show “MUTE”.

**SEL.(SELECT)/TRANSFER Button** – Allow you to save the changes for the listed items. In talk mode, this button allows you to transfer a call to another registered handset.

Note: During a call, when the user wants to transfer a call to another registered handset, the user must press the SEL/TRANSFER button and then press the telephone keypad ( 1, 2 ) designating the handset they are trying to transfer the call to. The call is quick transferred to the destination handset, the destination handset starts ringing and shows “FORWARDED CALL”. If destination handset user does not answer the call with 30 sec, source handset will be ring back after.

**MENU** – While in standby mode, this button allows you to set the handset in Programming mode.

**CHN (CHANNEL)** – While in Talk mode, it is used to manually select one of the 30 operating channels when you experience interference on the handset.

**Receiver** – Allows you to hear calls.

### **BASE UNIT CONTROLS:**

**Base Unit Charge Terminals** - Used for charging handset batteries. We recommend that you clean these contacts periodically with an alcohol-moistened cloth or cotton swab.

**IN USE/CHARGE LED Indicator** - Lights up steadily when the phone is in talk mode and turns off when the handset is not in use. It will flash when paging the handset. Lights up steadily when the handset is being charged on the base and turns off when the handset is removed from its cradle.

**PAGE Button** - Allows you to locate the handset when it is not on the base, or to alert the person near the handset.

**DC 9V jack** - A jack located on the rear side of the base unit used for connecting the AC adaptor to the base unit.

## **INSTALLATION**



**CAUTION: USE ONLY THE NICKEL CADMIUM (Ni-Cd) BATTERY TYPE INCLUDED WITH THIS UNIT. USE OF OTHER BATTERY TYPES MAY CAUSE INJURIES OR DAMAGE.**

1. Remove the battery compartment cover of the handset by pressing the top of the cover and sliding it down.
2. Connect the Ni-Cd battery pack plug along the slot into the handset's battery connector as shown below.

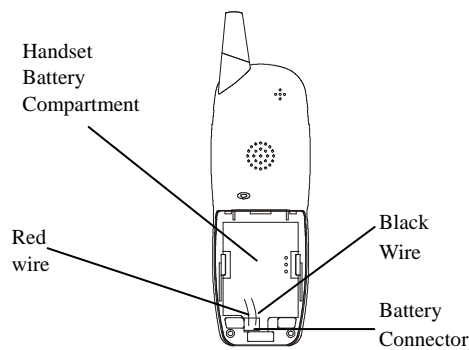

(Figure 1)

3. Insert the Ni-Cd battery into the battery compartment.
4. Replace the battery compartment cover by sliding it up towards the handset.

**NOTE:** Use the type and size of Ni-Cd battery pack, 3.6V, 450mAh. It is recommended that the Ni-Cd battery pack should be fully charged overnight prior to initial use.

### **Belt Clip Installation**

With the back of the handset facing up, insert one side of the belt clip hook into the matching slots at the top side of the handset as shown in Figure 2. Slide the other hook until it locks into place from the opposite side of the handset.

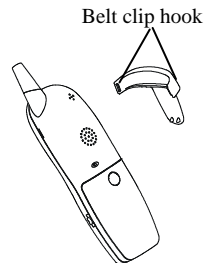

(Figure 2)

### **POWER CONNECTION**



**CAUTION:** You must use a Class II, 120 Volt AC/9 Volt DC adaptor that delivers at least 200mA for base unit and 200mA for charger. The center tip must be positive and the plug must correctly fit the base unit's DC 9V 200mA jack and fit the charger DC 9V 200mA jack.

1. Plug the AC adaptor into a standard AC outlet.
2. Insert the small plug into the DC 9V 20mA jack on the rear of the base unit and Insert the small plug into the DC 9V 200mA on the rear of the charger as shown in Figure 3.

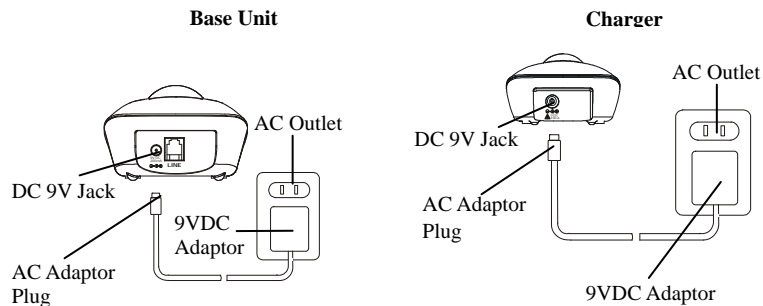

(Figure 3)

### **HEADSET CONNECTION**

One of the special features of your phone is that your handset could utilize a headset (not included) for hands-free communication. Insert the small plug at the end of your headset cord to the headset jack at the side of the handset as shown in Figure 4. Follow the procedures discussed in "Placing a Call" when to place and receive a call.

**Note:** The headset jack of your cordless telephone is compatible with 2.5mm headset plugs only. When you plug in the headset into the headset jack, it automatically mutes the microphone and speaker of the handset. Unplug the headset to return the handset to normal use.

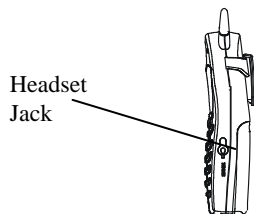

(Figure 4)

## **INITIAL SETUP**

Please follow these steps before using the cordless telephone for the first time.

1. Ensure that the handset battery pack is installed and charged fully for at least 14 hours.
2. Ensure that all connections (line cord and adapter cord) are properly inserted into the rear of the base unit.

## **TELEPHONE OPERATION**

### **PLACE A CALL**

1. Pick up the handset and press the TALK button. The LCD Display will show "PHONE ON". The base unit IN USE LED indicator will light up.
2. Listen for a dial tone.
3. Dial the telephone number. The phone numbers appear on the LCD Display as you enter the number.
4. When finished with your call, press the TALK button or place the handset on the base unit. The base IN USE LED indicator will turn off.

### **RECEIVE A CALL**

**NOTE:** If you are expecting incoming calls, the handset must be programmed to the RING 1, 2, 3, 4 mode.

#### **If the handset is on the base:**

1. When the phone rings, simply pick up the handset from the base cradle.
2. Start your conversation.
3. To end your conversation, either press the TALK button or place the handset on the base unit. The base IN USE LED indicator will turn off.

#### **If the handset is out of the base:**

1. When the phone rings, press the TALK button on the handset. The LCD Display will show "PHONE ON", the base unit IN USE LED Indicator and handset IN USE LED Indicator will light up.
2. Start your conversation.
3. To end your conversation, press the TALK button, the base IN USE LED Indicator and handset IN USE LED Indicator will turn off.

### **LAST NUMBER REDIAL**

#### **A. AFTER HEARING A BUSY TONE WHEN PLACING A CALL**

1. If you get a busy tone, press the handset TALK button to hang up.
2. Press the handset TALK button again and listen for a dial tone.
3. Press the handset RE/PA button. This will automatically redial the last telephone number you called.

(up to 32 digits).

4. When finished with your call, press the TALK button or place the handset on the base unit. The base IN USE LED indicator will turn off.

**B. WHEN THE HANDSET IS OFF THE BASE UNIT AND IN STANDBY MODE**

1. Press the TALK button on the handset and listen for a dial tone.
2. Press the RE/PA button. This will automatically redial the last telephone number that you called (up to 32 digits).
3. When finished with your call, press the TALK button or place the handset on the base unit. The base IN USE LED indicator will turn off.

**SAVING IN THE PHONEBOOK**

1. Press the MENU button.
2. Press the SEL/TRANSFER button.
3. Use the TELEPHONE KEYPAD button (0-9) to enter the name, (see the “TELEPHONE KEYPAD CHARACTERS SETTING” section) you can store up to 15 characters.
4. Press the SEL/TRANSFER button once.
5. Enter the telephone number using the TELEPHONE KEYPAD button (0-9). You can store up to 24 digits.
6. Press the SEL/TRANSFER button to save into memory, and then will automatically go back to standby mode.

**NOTE:** If there are no memory locations left in the phonebook, the unit will display “MEMORY FULL”. To continue with memory programming, you must delete or edit existing speed dial numbers. If no active buttons are pressed for 20 seconds, the LCD Display will automatically return to STANDBY mode.

**TELEPHONE KEYPAD CHARACTERS**

The TELEPHONE KEYPAD buttons (0-9) are used to enter the characters when entering names. Press the appropriate KEYPAD button to get the following characters.

KEYPAD BUTTON	CHARACTERS
1	1
2	A B C 2
3	D E F 3
4	G H I 4
5	J K L 5
6	M N O 6
7	P Q R S 7
8	T U V 8
9	W X Y Z 9
0	0
*	*
#	& ' , - . #

For example, if you want to enter the character “C”, press the “2” KEYPAD button. The first character displayed will be “A”. Press the “2” button again to display “B”, and press the “2” button again to display the letter “C”.

### VIEWING THE PHONEBOOK

This Phonebook lets you scroll through the list to find the person you need for one touch dialing. You can store up to 20 names and telephone numbers in the Memory.

1. Press the **UP** button.
2. Press the **UP** or **DN** button to find the one you need.



**NOTE:** To exit the Phonebook at anytime, Press the EXIT button.

### EDITING NAME AND NUMBER IN THE PHONEBOOK

1. Press the **UP** button.
2. Press the **UP** or **DN** button to find the one you want to edit.
3. Press the SEL/TRANSFER button, the LCD will show "QUICK EDIT ERASE" and then press the **UP** or **DN** to select "EDIT". Press the SEL/TRANSFER button to confirm a selection.
4. Press the TELEPHONE KEYPAD button to edit the name.



5. Press the **UP** or **DN** button to move to the letter or number you want to change.  
To erase, press the **DN** Button to remove previous letter, press the **UP** button a second time will produce a space  
To add, use the TELEPHONE KEYPAD buttons (0-9).
6. Press the SEL/TRANSFER button to edit the number.
7. Press the **DN** button to move the cursor to the number you want to change.  
To erase, press the **DN** button to remove previous number.  
To add, use the TELEPHONE KEYPAD buttons (0-9).



8. Press the SEL/TRANSFER button to confirm.

**NOTE:** When no active buttons are pressed for 20 seconds, the LCD Display will automatically return to STANDBY mode.

### PLACING CALLS FROM THE PHONEBOOK

1. Press the **UP** button.
2. Press the **UP** or **DN** button to find the contact you want to call.
3. Press the TALK button to dial out the telephone number.
4. Start your conversation.
5. To end your conversation, either press the TALK button or place the handset on the base unit.

**NOTE:** Be sure to check that the line is not in use by another extension.

### **DELETING A STORED NUMBER**

1. Press the **UP** button.
2. Press the **UP** or **DN** button to find the one you want to delete.
3. Press the SEL/TRANSFER button. The LCD Display will show “QUICK EDIT ERASE”.
4. Press the **UP** or **DN** button to select “ERASE”, and then press the SEL/TRANSFER button. The LCD will show “ERASE NO YES”.
5. Press the **UP** or **DN** button to select “YES” and then press the SEL/TRANSFER button to confirm a deletion.
6. Press the EXIT button to return to STANDBY mode.

### **MIXED MODE DIALING (Temporary Pulse to Tone Dialing)**

1. If you only have pulse (rotary dialing) service in your area and want to access Tone services (Bank by Phone , etc.), ensure that the unit is set to the Pulse position.
2. Press the TONE (\*) button once to switch from Pulse to Tone dialing temporarily. Pulse dialing mode resumes when the call is ended.

### **PAUSE FUNCTION**

- In some cases, such as PABX or long distance service, a pause may be needed in the dialing sequence. Pressing the handset RE/PA button inserts the programmed time interval between dialed numbers.

### **FLASH FUNCTION**

- Used to access custom calling features such as Call Waiting or Three-Way Calling provided by your local phone company. Flash can also be used to restore a dial tone to make a new call.

### **CHANNEL SELECTION (30 Channels)**

- Your cordless telephone lets you select a channel from the 30 frequencies available to transmit signals between the base unit and handset. If the existing channel becomes noisy or starts having interference, you can either move closer to the base unit or press the CHN button on the handset until a better reception is found.

### **LOW BATTERY WARNING**

- When the handset battery voltage level is low, the handset LCD Display shows symbol “” at the lower left corner of handset and “BATTERY LOW” at the top left corner of handset and a beep sounds.
- Return the handset on the base cradle to charge.

### **PAGING FUNCTION**

- If you have misplaced the handset or need to alert person nearby the handset, press the PAGE button on the base unit. Each press of this button will activate the handset to beep for 60 seconds and LCD Display shows “PAGING” and the base IN USE LED Indicator will start to blink. Press again to stop.

**NOTE:** Even if the handset is in RING OFF mode, the base unit can page the handset.

## **CALLER ID OPERATION**

### **GETTING TO KNOW YOUR NEW PHONE**

**IMPORTANT:** Subscription to Caller ID (CID)/Call Waiting ID services from your local phone company is required for using the Caller ID/Call Waiting ID features of the TLC-353. Your new TLC-353

telephone gives you the ultimate in cordless telephone sound quality with the luxury of Caller ID and Call Waiting ID.

If this is your first cordless telephone, you will soon discover that your cordless is similar to regular telephones, except without the cord. If you have owned a cordless in the past, you will discover that the TLC-353 telephone is the most powerful and full-functioned Call Waiting ID cordless telephone on the market, some key features are:

- 50 name and number Caller ID/Call Waiting ID memory (Call List)
- 20 name and number programmable memory (Phonebook)
- Hearing – aid compatibility
- Automatic or manual selection of the clearest of 30 channels

Unlike regular telephones, your cordless telephone does not work during power failures. We do not recommend that you use a cordless telephone as the only phone in your residence.

### **INTRODUCTION TO CALLER ID AND CALL WAITING ID**

The TLC-353 Caller ID/Calling Waiting ID devices allow you to take advantage of the Caller identification delivery service offered by your local telephone company. For more information, you can refer to the following Question and Answer table:

QUESTIONS	ANSWERS
What is Caller ID?	Caller ID is a device that identifies the calling party before you answer a call. This device can be used to screen unwanted calls and eliminate harassment from annoying calls.
What is Caller Waiting ID?	Call Waiting ID is a device that can also identifies the call waiting party before you answer a call.
How does Caller ID and Call Waiting ID work?	When used with Caller ID/Call Waiting service, the Caller ID/Call Waiting ID device displays the name (if available), and the telephone number (if available) of the person calling before you answer your telephone.
Who provides Caller ID service?	Your local telephone company. However, not all local telephone companies provide Caller ID service. Please call you local phone company to confirm that the service is available before you install the device.
How can I activate my Caller ID?	For you Caller ID unit to function, you must first arrange with your local telephone company to have Caller ID/Call Waiting ID service installed on you line. There is an extra charge added to your monthly telephone bill for this service. Before using this unit, please read this instruction manual carefully.

### **RECEIVING NEW CALL**

- When you receive a new call, the call information is stored under CALLER ID List. The “NEW NUMBER” segment of LCD Display if there is new call (s).
- When you receive a call, the system displays the caller information sent by the telephone company, called a Call Record. The Call Record consists of the following information:
  - a. The caller’s name (if available)
  - b. The caller’s telephone number
  - c. The date and time of the call

<b>JOHN SMITH</b>
<b>555-</b>
<b>555-1212</b>
12/15 10:00 <sup>AM</sup>

- If there is no call records, the LCD display shows “CID EMPTY” by pressed the **DN** button.

#### VIEWING THE CALLER ID LIST

1. In standby mode, press the **DN** or **CALL** button to enter Caller ID list. If there is new call(s), the new call (s) will be displayed at first.



2. Press the **DN** button to scroll to the next call. The **DN** button will go through the calls from the last call received to the first. The **UP** button will allow you to view the calls from the first call received to the last.
3. Press the **EXIT** button to finish.

**NOTE:** If no active buttons are pressed for 20 seconds, the LCD Display will automatically return to STANDBY mode.

#### CALLER ID DISPLAY

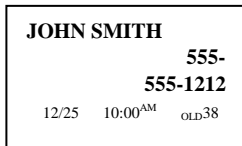

This display shows the name, number, time and date of the call.

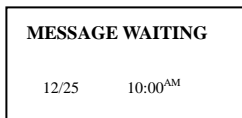

Display shows when a voice mail message has been received and is stored by message waiting service provided by the phone company.

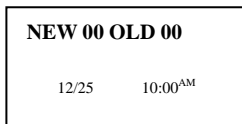

This is displayed when there is no Caller ID date stored.

**NOTE:** If a call is received from the same number more than once since the records were last viewed, no new entry is made, but the repeat call icon “\*” and the number of repeat calls is displayed.

#### CALL WAITING

When you subscribe to Call Waiting service from your local telephone Company, this telephone will display the name and number of the second caller while you are having a conversation.

1. When a second call comes in while you are having a conversation, you will hear a notification tone from the handset and volume is momentarily muted. The LCD Display will automatically shows the name and number of the second caller.
2. Press the **FLASH** button to answer the second caller.
3. When you are finished, press the **FLASH** button to continue your conversation with the first caller.

### MESSAGE WAITING

If you have subscribed to the Voice Mail message service and you have requested Visual Message Indication from your local telephone company, the IN USE/MSG WTG/NEW CALL/VISUAL RINGER LED indicator will blink and the LCD Display will show "MESSAGE WAITING" when there are voice message(s) for you. To remove the MESSAGE WAITING indicator, see the "Message Waiting Setting" section.



### PLACING A CALL FROM THE CALLER LIST

1. Press the **DN** or **CALL** button.
2. Press the **UP** or **DN** button to select the call record you wish to call back.
3. If the number displayed is not correct (needing 7, 10, 11 digits), press the # button to select call number.

11 digit number  
displayed as below:

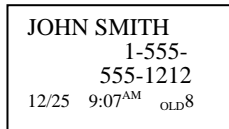

Press # button

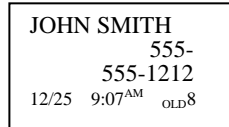

Press # button

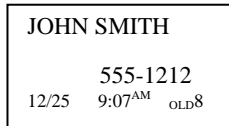

Press # button

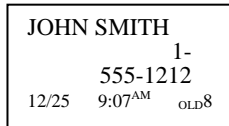

10 digit number  
displayed as below:

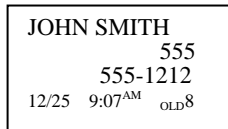

Press # button

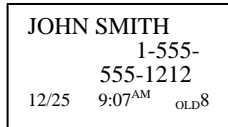

Press # button

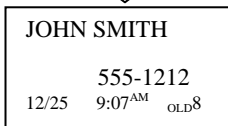

Press # button

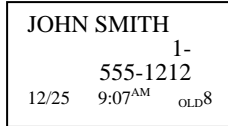

7 digit number  
displayed as below:

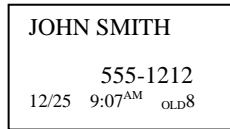

Press # button

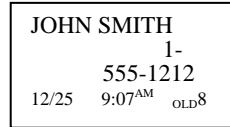

4. Press the **TALK** button to dial out.
5. To end your conversation, either press the **TALK** button or place the handset on the base unit.

### **SAVING THE NAME AND NUMBER FROM THE CALLER LIST INTO PHONE BOOK**

1. Press the **DN** or **CALL** button
2. Press the **UP** or **DN** button to scroll to the call record you wish to delete.
3. Press the SEL/TRANSFER button. The LCD Display will show "DIAL ERASE STORE". Press the UP or DOWN button to select "STORE", and then press the SEL/TRANSFER button to confirm a selection.
4. Press the SEL/TRANSFER button twice to confirm.
5. Press the EXIT button to return to STANDBY mode.

### **SELECTIVE DELETING IN THE CALLER LIST**

1. Press the **DN** or **CALL** button
2. Press the **UP** or **DN** button to scroll to the call record you wish to delete.
3. Press SEL/TRANSFER button. The LCD Display will show "DIAL ERASE STORE"
4. Press the **UP** or **DN** button to select "ERASE", and then press the SEL/TRANSFER button to confirm a selection. The LCD will show "ERASE NO YES ALL".
5. Press the **UP** or **DN** button to select "YES", and then press the SEL/TRANSFER button to confirm a deletion the call record.
6. Press the EXIT button to return to STANDBY mode.

### **DELETING ALL RECORDS IN THE CALLER LIST**

1. Press the **DN** or **CALL** button
2. Press the **UP** or **DN** button to scroll to the call record you wish to delete.
3. Press the SEL/TRANSFER button. The LCD Display will show "DIAL ERASE STORE"
4. Press the **UP** or **DN** button to select "ERASE", and then press the SEL/TRANSFER button to confirm a selection. The LCD will show "ERASE NO YES ALL".
5. Press the **UP** or **DN** button to select "ALL", and then press the SEL/TRANSFER button to confirm a deletion the call record. The LCD Display will show "ERASE ALL NO YES", And then press the **UP** or **DN** button to select "YES".
6. Press the SEL/TRANSFER button to confirm, and then will automatically go back to standby mode.

### **PROGRAMS OPERATION**

This unit contains the following special Programs:

- A. PHONE BOOK
- B. LANGUAGE
- C. MESSAGE WAITING
- D. DIAL MODE
- E. DATE/TIME
- F. RINGER
- G. QUICK DIAL

#### **A. *PHONE BOOK***

<b>PHONE BOOK</b>
-------------------

You can edit 20 directory memories.

1. Press the MENU button.
2. Press the SEL/TRANSFER button.

3. Use the TELEPHONE KEYPAD button (0-9) to enter the name, (see the “TELEPHONE KEYPAD CHARACTERS SETTING” section ) you can store up to 15 characters.
4. Press the SEL/TRANSFER button once.
5. Enter the telephone number using the TELEPHONE KEYPAD button (0-9). You can store up to 24 digits.
6. Press the SEL/TRANSFER button to save into memory, and it will automatically go back to standby mode.

**B. LANGUAGE**

<b>LANGUAGE</b>
-----------------

This telephone offers English, Spanish and French languages for your convenience.

1. Press the MENU button.
2. Press the **UP** or **DN** button to select LANGUAGE.
3. Press the SEL/TRANSFER button to confirm.
4. Press the **UP** or **DN** button to select English, Spanish and French.
5. Press the SEL/TRANSFER button to save the setting, and it will automatically go back to standby mode.

**C. MESSAGE WAITING**

<b>MESSAGES WAITING</b>
-------------------------

To turn off the Message Waiting LCD indicator.

1. Press the MENU button.
2. Press the **UP** or **DN** button to select MESSAGES WAITING
3. Press the SEL/TRANSFER button to confirm.
4. Press the **UP** or **DN** button to select YES or ON.
5. Press the SEL/TRANSFER button to confirm, and it will automatically go back to standby mode.

**D. DIAL MODE**

<b>DIAL MODE: TONE</b>
------------------------

Allows you to set the dialing mode to either Tone dialing or Pulse dialing.

1. Press the MENU button.
2. Press the **UP** or **DN** button to select DIAL MODE.
3. Press the SEL/TRANSFER button to confirm.
4. Press the **UP** or **DN** button to select TONE or PULSE.
5. Press the SEL/TRANSFER button to save the setting, and it will automatically go back to standby mode.

**E. DATE/TIME**

<b>DATE/TIME</b>
------------------

Set the date and time.

1. Press the MENU button.
2. Press the **UP** or **DN** button to select DATE/TIME.
3. Press the SEL/TRANSFER button to confirm.
4. Use the **UP** or **DN** button to enter the month, and then press the SEL/TRANSFER button to confirm.
5. Repeat step 4 above to set the date, hour and minute.
6. Press the **UP** or **DN** for AM or PM setting., and then press the SEL/TRANSFER button to save the setting, and then will automatically go back to STANDBY mode.

**NOTE:** The date and time will automatically set, if you have subscribed to the Caller ID service from your local telephone company.

#### **F. RINGER**

**RINGER: 1**

1. Press the MENU button.
2. Press the **UP** or **DN** button to select RINGER.
3. Press the SEL/TRANSFER button to confirm.
4. Press the **UP** or **DN** button to select the RING (1,2,3,4, OFF). The 1 ringer is the preset mode.
5. Press the SEL/TRANSFER button to confirm, and it will automatically go back to standby mode.

#### **G QUICK DIAL**

**QUICK DIAL**

Allows you to save 9 programmed telephone numbers into the memory.

1. Press the MENU button.
2. Press the **UP** or **DN** button to select QUICK DIAL.
3. Press the SEL/TRANSFER button to confirm.
4. Press a number (0-9) on the keypad, where you want the number stored.
5. Use the TELEPHONE KEYPAD button (1-9) to enter the name, (see the "TELEPHONE KEYPAD CHARACTERS SETTING" section ) you can store up to 15 characters.
6. Press the SEL/TRANSFER button to confirm.
7. Enter the telephone number using the TELEPHONE KEYPAD button (0-9). You can store up to 24 digits.
8. Press the SEL/TRANSFER button to save the setting, and it will automatically go back to standby mode.

**STORE the name and number into QUICK DIAL from the phone book**

- a) Press the **UP** button.
- b) Press the **UP** or **DN** button to select the one you desire.
- c) Press the SEL/TRANSFER button .
- d) Press the **UP** or **DN** button to select " QUICK".
- e) Press the SEL/TRANSFER button.
- f) Press a number (1-9) on the key pad you want to store.
- g) Press the EXIT button to go back to STANDBY mode.

**Dial 9 Frequently Called Numbers**

- a) In STANDBY mode, press and hold a number on the keypad where the desired phone number is stored.
- b) Press TALK button to dial. Or , if you don't want to dial. You can press the EXIT button to return the standby mode.

#### **REGISTER HANDSET**

1. Press and hold PAGE button until you plug the AC adaptor plug into DC jack (located on the rear of the base units), and then the base IN USE LED will flash.
2. Release the PAGE button.
3. Press the MENU button, and then press the telephone keypad "1,2,3,1" button. You will listen a beep sounds. The LCD will display REGISTRATION.
4. Place the handset on the base unit to register.
5. Pick up the handset to go back to STANDBY mode.
6. Disconnect the AC adaptor plug and reconnect the AC adaptor plug will return back to STANDBY mode.

**Note:** If the handset does not link to base unit, you must register handset. If the handset normally link to base unit, you don't need to register handset.

#### **1,048,576 COMBINATION SECURITY CODING**

The cordless telephone has a digital coding security system to prevent unauthorized use of your telephone line by other cordless phones nearby. The cordless telephone have 1,048,576 possible security code combinations. Each combination of the code is randomly generated by factory equipment.

#### **IMPROVING CORDLESS RECEPTION**

Follow these guidelines to improve cordless sound quality:

- Select an area to install the unit where it is closest to the center of your home or office. This will improve the operating range of the unit.
- Keep the base unit away from electrical equipment. Radio Frequency Interference (RFI) is sometimes generated by these appliances, which can cause a degradation in cordless reception.
- Keep the handset batteries charged as much as possible. Weak handset batteries can limit the range of cordless operation.

#### **MAXIMIZING BATTERY LIFE**

Repeated use, or recharge of Ni-Cd batteries without periodic full discharge results in reduced useable charge time. When you notice the usable charge duration decreasing, fully discharge the Ni-Cd battery and recharge as described:

##### **DISCHARGING**

1. Unplug the telephone line cord from the TLC-353.
2. Make sure that the adapter is connected.
3. Lift the handset out of the base cradle.
4. Press the TALK button on the handset and start discharging..

Once the Symbol LOW Battery appears on LCD display, it means that the battery level is low. Let it fully discharge for 12 hours. Once the Ni-Cd battery is fully discharged, you may now charge the battery to its full capacity.

##### **CHARGING**

1. Make sure the adapter and telephone line cord are connected to the TLC-353.
2. Place the handset on the base cradle. The CHARGE LED indicator of the base unit will light steadily.

3. Leave the handset charging on the base for 14 hours continuously to get a maximum charge.
4. The TLC-353 is now ready for regular use. Discharge and charge the Ni-Cd battery again once you notice a decrease in the useable charge time.

### **MAINTENANCE**

1. Your phone should be situated away from heat sources such as radiators, heaters, stoves or any other appliance that produces heat.
2. Use a slightly damp cloth to clean the plastic cabinet. A mild soap will help to remove grease or oil. Never use polish, solvents, abrasives or strong detergents since these can damage the finish.

### **TECHNICAL INFORMATION**

This cordless phone uses radio frequencies to allow mobility. There are certain difficulties in using radio frequencies with a cordless telephone. While these are normal, the following could affect the operation of your system.

**NOISE:** Electric pulse noise is present in most homes at one time or another. This noise is most intense during electrical storms. Certain kinds of electric equipment such as light dimmers, fluorescent bulbs, motors, and fans also generate noise pulses. Because radio frequencies are susceptible to these noise pulses, you may occasionally hear them in your handset. Generally, they are minor annoyances and should not be interpreted as defects in your system.

**RANGE:** Because radio frequencies are used, location of the base unit can affect operating range. Try several locations in your home or business and pick the one that gives you the clearest signal.

**INTERFERENCE:** Some electronic devices operate in and/or generate interference near the operating frequencies of your cordless telephone. While several protection circuits are used to prevent unwanted signals, there may be periods when these unwanted signals cause interference. If interference occurs frequently, it can be minimized or eliminated by lowering the height of your base antenna or by relocating the base unit. You can check for interference before selecting the final base unit location by plugging in the phone.

## **TROUBLESHOOTING**

### **A. TELEPHONE UNIT TROUBLESHOOTING TABLE**

<b>SYMPTOM</b>	<b>SOLUTION</b>
No dial tone	<ul style="list-style-type: none"> <li>• Check the telephone line cord connectors at both ends that they are pushed in firmly until they click.</li> <li>• If you had a power failure or had unplugged the base unit, replace the handset on the base unit for two to five seconds to reset the system.</li> </ul>
Does not ring	<ul style="list-style-type: none"> <li>• Check the RING 1,2,3,4 and OFF mode on the handset. Set to RING 1,2,3,4 mode to enable the handset ringer.</li> <li>• Check the telephone line cord connectors at both ends that they are pushed in firmly until they click.</li> <li>• You may have exceeded the Ringer Equivalence Number (REN) limit of how many phones can be connected to the same line. The REN total of all devices(printed on the bottom label of each unit)should not exceed five(5). Disconnect the appropriate units to lower the REN total.</li> </ul>
No power on the handset unit	<ul style="list-style-type: none"> <li>• Check the Ni-Cd battery pack for proper connection inside the battery compartment on the handset.</li> <li>• The handset rechargeable Ni-Cd pack may need charging.</li> </ul>
Does not charge	<ul style="list-style-type: none"> <li>• Check the Ni-Cd battery pack for proper connection inside the battery compartment on the handset.</li> <li>• Made sure the charging contacts on both the base unit and the handset are in contact during charging.</li> <li>• The charging contacts and terminals may need cleaning with an alcohol-dampened swab.</li> </ul>
Range is limited	<ul style="list-style-type: none"> <li>• Move the base unit so that it is centrally located in your residence or office and make sure that the base unit is not located near appliances.</li> <li>• The handset Ni-Cd battery may be weak. Recharge the Ni-Cd battery.</li> <li>• Refer to the section “ Improving Cordless Reception”.</li> </ul>
Calls received flutters or fades	<ul style="list-style-type: none"> <li>• The handset rechargeable Ni-Cd battery pack may need charging.</li> <li>• Choose an alternate channel using the CHN button on the handset.</li> </ul>
Interference on reception	<ul style="list-style-type: none"> <li>• Refer to the section “Improving Cordless Reception”.</li> </ul>
Excessive static	<ul style="list-style-type: none"> <li>• Refer to the section “Improving Cordless Reception”.</li> </ul>

**B. CALLER ID SYSTEM TROUBLESHOOTING TABLE**

SYMPTOM	SOLUTION
The Caller ID panel is blank	<ul style="list-style-type: none"> <li>• Check the power connection.</li> <li>• Check the telephone line cord connections.</li> <li>• Check the batteries for proper installation.</li> </ul>
The Caller ID does not show the caller's name and/or phone number	<ul style="list-style-type: none"> <li>• The Caller ID unit will not function until you have Caller ID service provided by your local phone company. Call your local phone company to have Caller ID installed onto your telephone line</li> <li>• If you pick up the phone before the second ring, the caller information will not be correctly received. If you have a telephone answering device(TAD) connected with the unit, set the TAD to answer after two rings or more.</li> <li>• If it is a blocked call or an out-of-area call, the caller's name and/or phone number will not appear on the display.</li> <li>• If only the caller's phone number appears on the display, it may be a Single Data Message Format (SDMF) call, as opposed to a Multiple Data Message Format (MDMF) call. Please call your local phone company to see which service you have.</li> </ul>
Random characters and/or "NO DATA" appear on the LCD display	<ul style="list-style-type: none"> <li>• On rare occasions, the Caller ID information sent by the telephone company may have an error in the transmission. This is not the fault of your Caller ID unit. It can only capture and store the data that was received.</li> </ul>
Cannot get call Waiting identification on the LCD panel	<ul style="list-style-type: none"> <li>• Subscription to Caller ID Call Waiting (CIDCW) is required from your local phone company for the CIDCW function to operate properly. Call you local phone company for details.</li> </ul>

**AC ADAPTOR: USE ONLY WITH CLASS 2 POWER SOURCE, OUTPUT 9VDC, 20mA for base unit and 200mA for charger .**



**THIS SYMBOL IS INTENDED TO ALERT THE USER OF THE PRESENCE OF IMPORTANT OPERATING AND MAINTENANCE (SERVICING) INSTRUCTIONS IN THE OWNER'S MANUAL.**